



BRAMBLE

PRODUCT TEARSHEET



Charleston Nightstand Small

Shown in: **FOR LDT**

SKU: **25446**

Size: **28W x 16D x 28H in**



Overview

The Charleston Nightstand further enhances the elegant look of a sophisticated boudoir motif. Its solid mahogany construction highlights gorgeous design accents such as dove tail drawers, ornate carvings, and bun feet. This piece is offered with a vast array of finish and distress options to create a truly custom design.

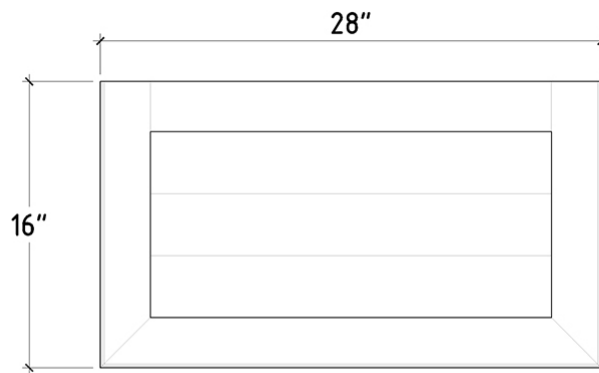

TOP VIEW

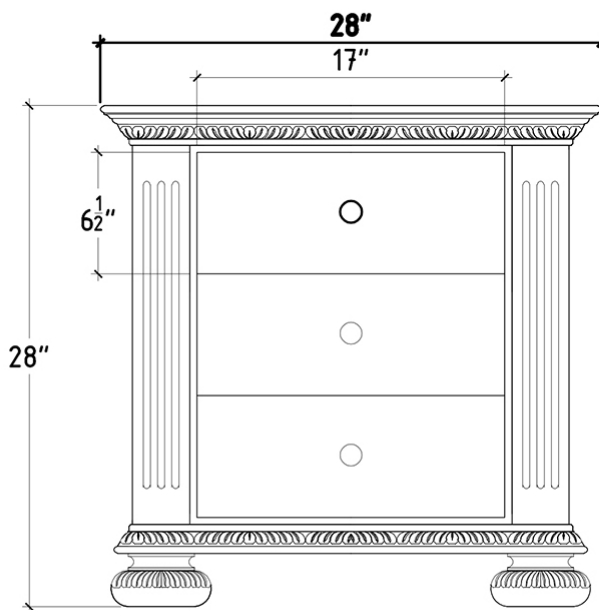

FRONT VIEW

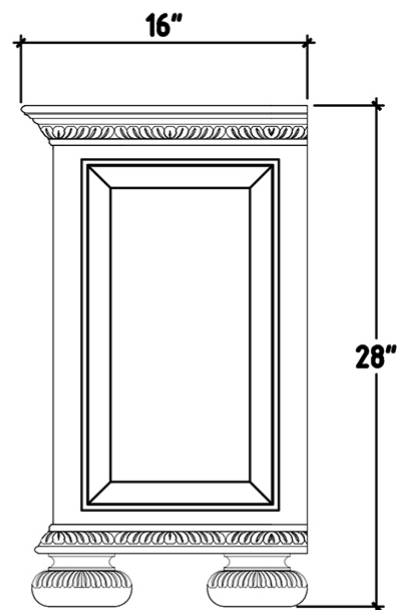

SIDE VIEW

Visual Highlights



Technical Specification

Dimensions	28W x 16D x 28H in	CBM	0.25
Number of Packages	1	Cubic Feet	8.83 ft³
Package 1 Dimensions	30.7 x 18.9 x 33.1 in	Package 1 Weight	88.18 lbs
Package Weight Total	88.18 lbs	Net Weight	77.16 lbs
Material	Mahogany		

<https://www.brambleco.com/25446>
