

EST. *B* 1991

BRAMBLE

PRODUCT TEARSHEET



Summerville Small Nightstand Cabinet

Shown in: **DRW**

SKU: **23496**

Size: **20W x 15D x 27H in**



Overview

Add a subtle accent to any bedroom with this small Shutter Nightstand Cabinet. Offering sizeable storage space and a shutter style door, this nightstand is the perfect cross between charm and convenience. This piece is offered with a vast array of finish and distress options to create a truly custom design.

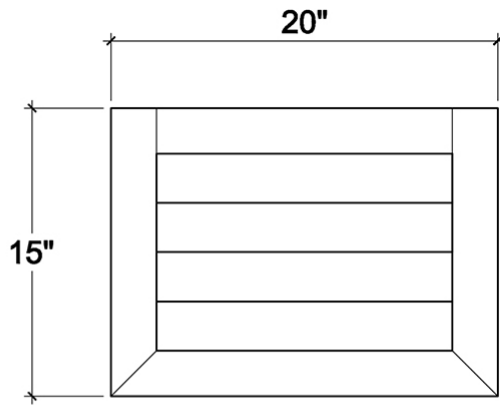

TOP VIEW

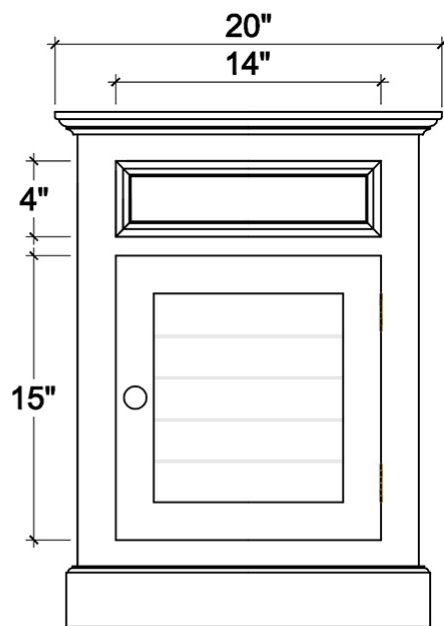

FRONT VIEW

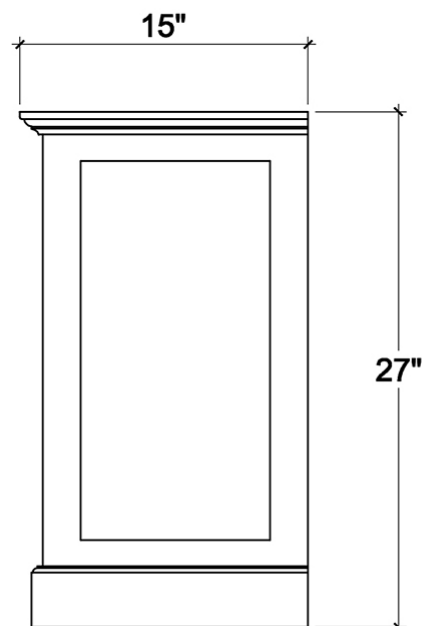

SIDE VIEW

Visual Highlights



Technical Specification

Dimensions	20W x 15D x 27H in	CBM	0.17
Number of Packages	1	Cubic Feet	6 ft³
Package 1 Dimensions	21.7 x 16.5 x 29.5 in	Package 1 Weight	37.48 lbs
Package Weight Total	37.48 lbs	Net Weight	30.86 lbs
Material	Mahogany		

<https://www.brambleco.com/23496>
