



BRAMBLE

PRODUCT TEARSHEET



Martinique Counter Stool

Shown in: **WHD SF204**

SKU: **27921**

Size: **20W x 22D x 43H in**



Overview

Martinique Counter Stool

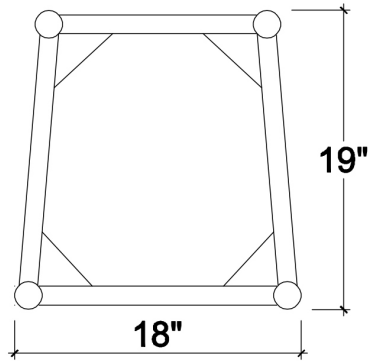

TOP VIEW

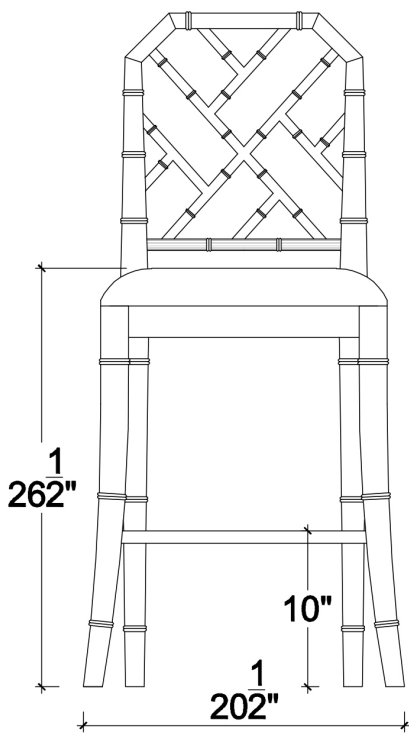

FRONT VIEW

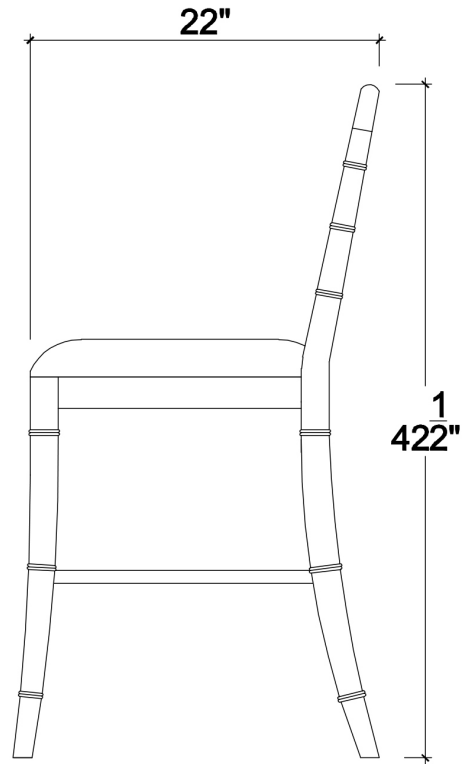

SIDE VIEW

Visual Highlights



Technical Specification

Dimensions	20W x 22D x 43H in	CBM	0.28
Number of Packages	1	Cubic Feet	9.89 ft³
Package 1 Dimensions	19.7 x 23.6 x 45.3 in	Net Weight	26.46 lbs
Package Weight Total 33.07 lbs			
Material	Mahogany		

<https://www.brambleco.com/27921>
