

EST. *B* 1991

BRAMBLE

PRODUCT TEARSHEET



Mornington Linen Wrapped 3 Drawer Dresser

Shown in: **FPBE**

SKU: **76584**

Size: **42W x 20D x 36H in**



Overview

Mornington 3 Drawer Dresser

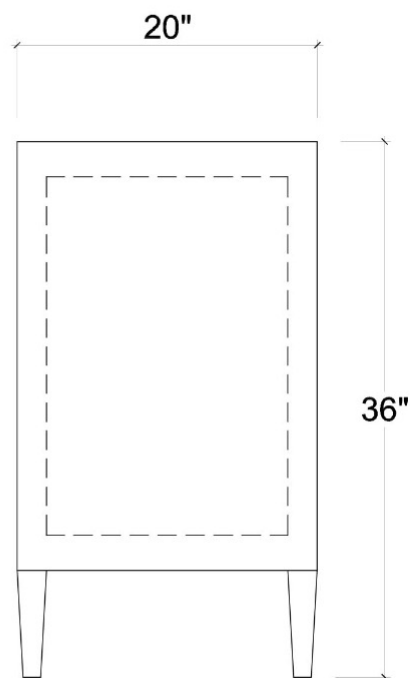
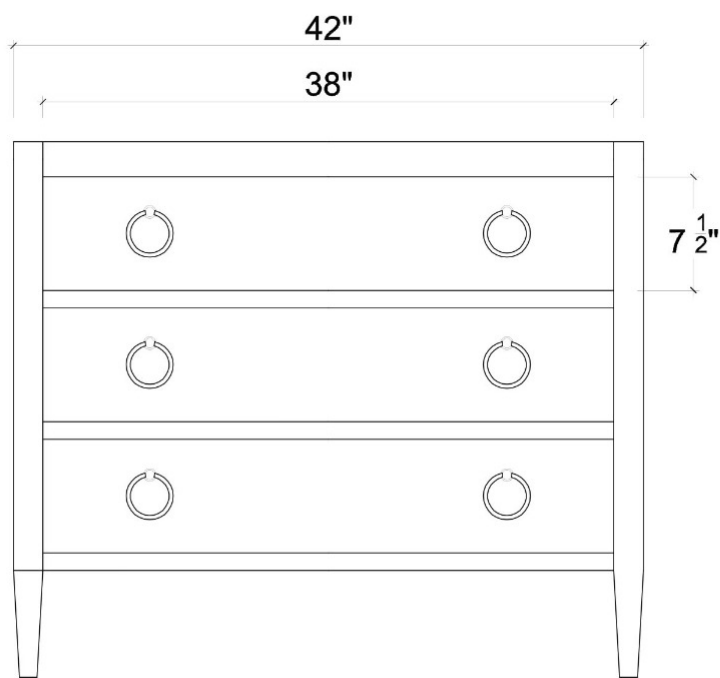
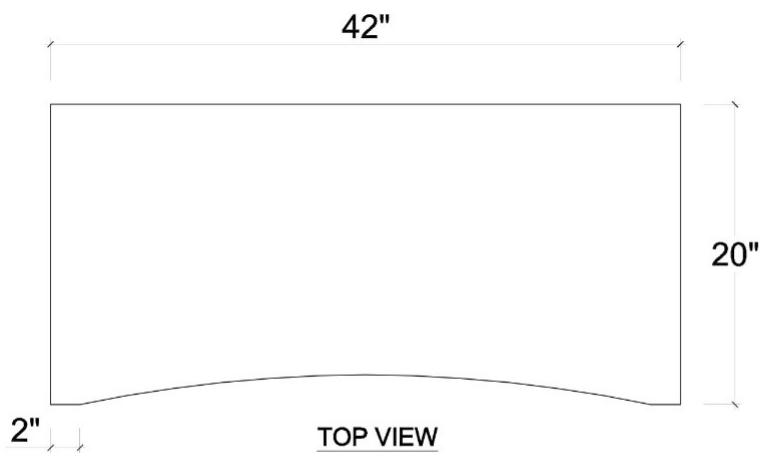

Visual Highlights





Technical Specification

Dimensions	42W x 20D x 36H in	CBM	0.6
Number of Packages	1	Cubic Feet	21.19 ft³
Package 1 Dimensions	46.5 x 21.7 x 41.7 in	Package 1 Weight	147.71 lbs
Package Weight Total	147.71 lbs	Net Weight	136.69 lbs
Material	Mahogany		

<https://www.brambleco.com/76584>
