



BRAMBLE

PRODUCT TEARSHEET



# Fulham Linen Wrapped Nightstand

---

Shown in: **FPUT**

SKU: **76583**

Size: **19W x 15D x 26H in**



## Overview

---

Fulham Nightstand

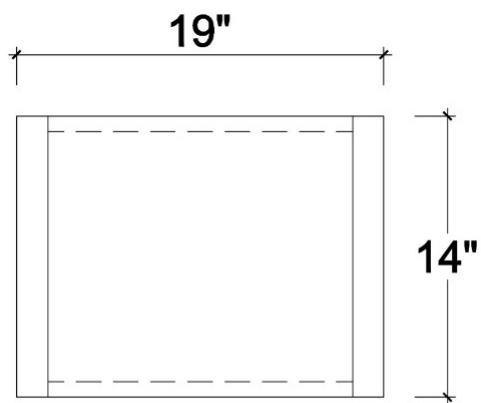

TOP VIEW

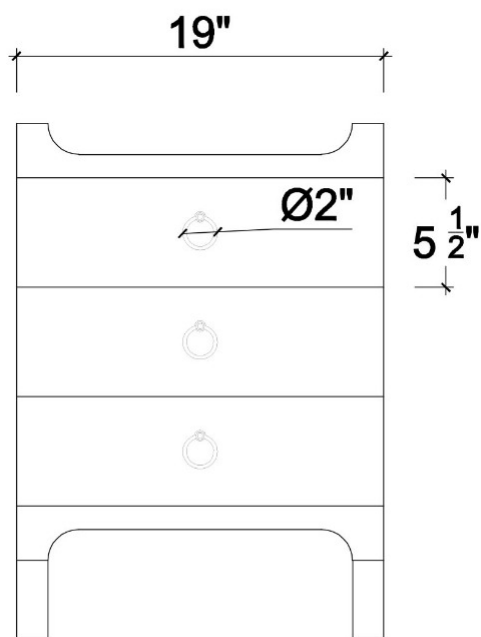

FRONT VIEW

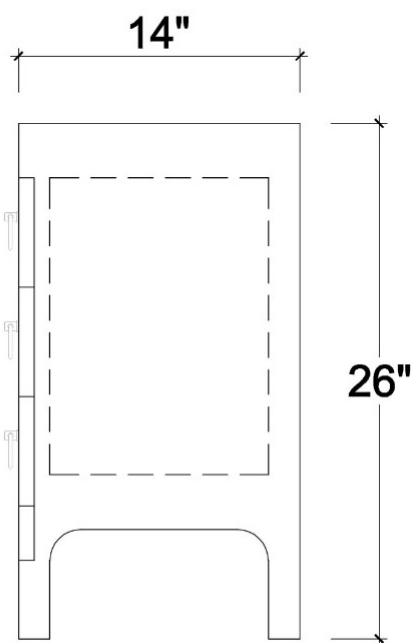

SIDE VIEW

## Visual Highlights

---

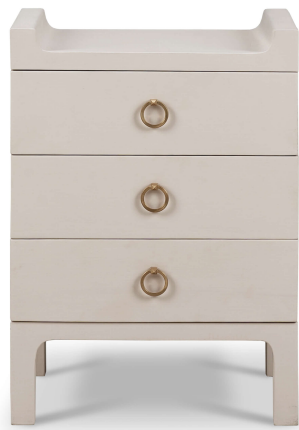

## Technical Specification

---

Dimensions	<b>19W x 15D x 26H in</b>	CBM	<b>0.16</b>
Number of Packages	<b>1</b>	Cubic Feet	<b>5.65 ft<sup>3</sup></b>
Package 1 Dimensions	<b>20.1 x 16.5 x 28.7 in</b>	Package 1 Weight	<b>38.58 lbs</b>
Package Weight Total	<b>38.58 lbs</b>	Net Weight	<b>35.27 lbs</b>
Material	<b>Mahogany, Rattan, Fabric</b>		

<https://www.brambleco.com/76583>

---