



BRAMBLE

PRODUCT TEARSHEET



# Fulham Linen Wrapped End Table /Nightstand

---

Shown in: **FPUT**

SKU: **76581**

Size: **30W x 16D x 30H in**



## Overview

---

Fulham End Table

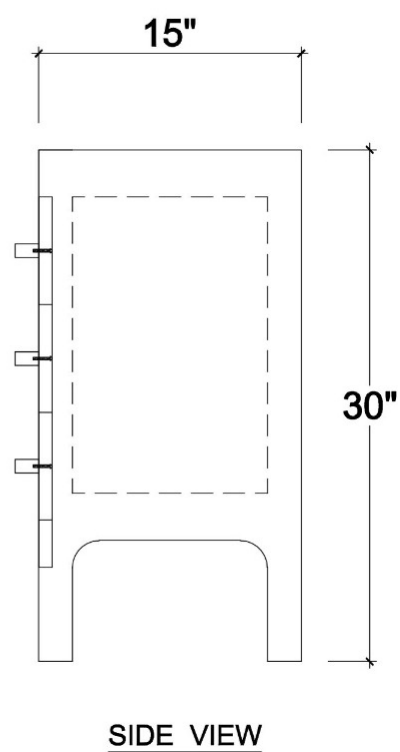
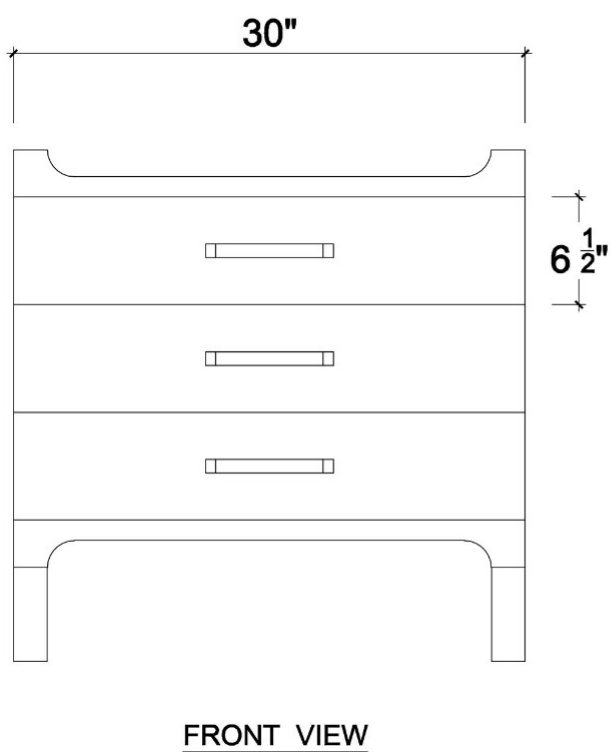
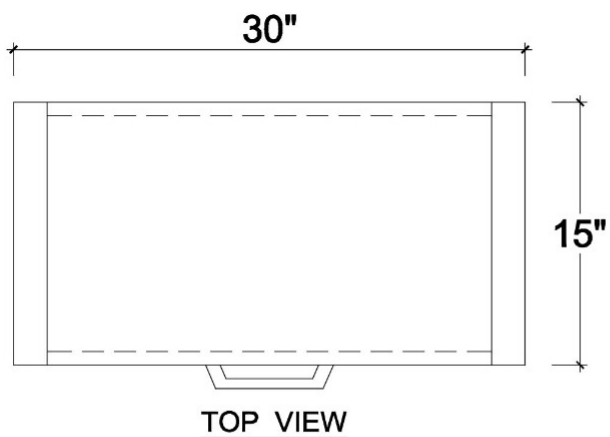

## Visual Highlights

---





## Technical Specification

---

Dimensions	<b>30W x 16D x 30H in</b>	CBM	<b>0.3</b>
Number of Packages	<b>1</b>	Cubic Feet	<b>10.59 ft<sup>3</sup></b>
Package 1 Dimensions	<b>31.5 x 17.7 x 32.7 in</b>	Package 1 Weight	<b>52.91 lbs</b>
Package Weight Total	<b>59.52 lbs</b>	Net Weight	<b>52.91 lbs</b>
Material	<b>Mahogany, Rattan, Fabric</b>		

<https://www.brambleco.com/76581>

---