

EST. *B* 1991

BRAMBLE

PRODUCT TEARSHEET



Laurel Wing Chair

Shown in: **STW SF200**

SKU: **27447**

Size: **31W x 34D x 48H in**



Overview

Laurel Wing Chair

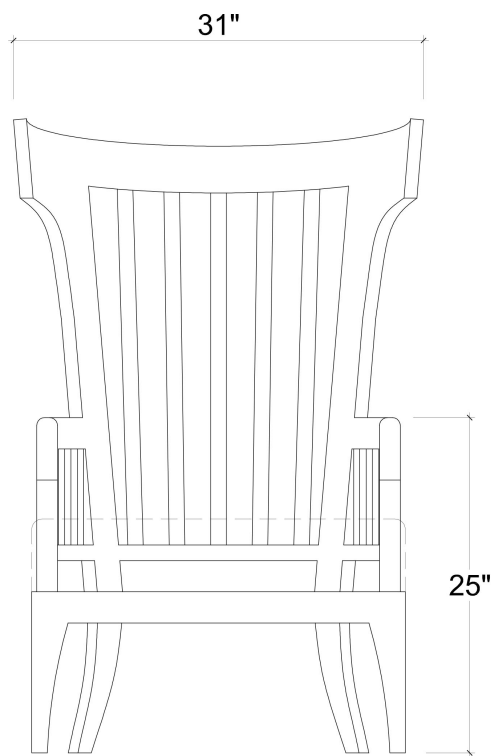

FRONT VIEW

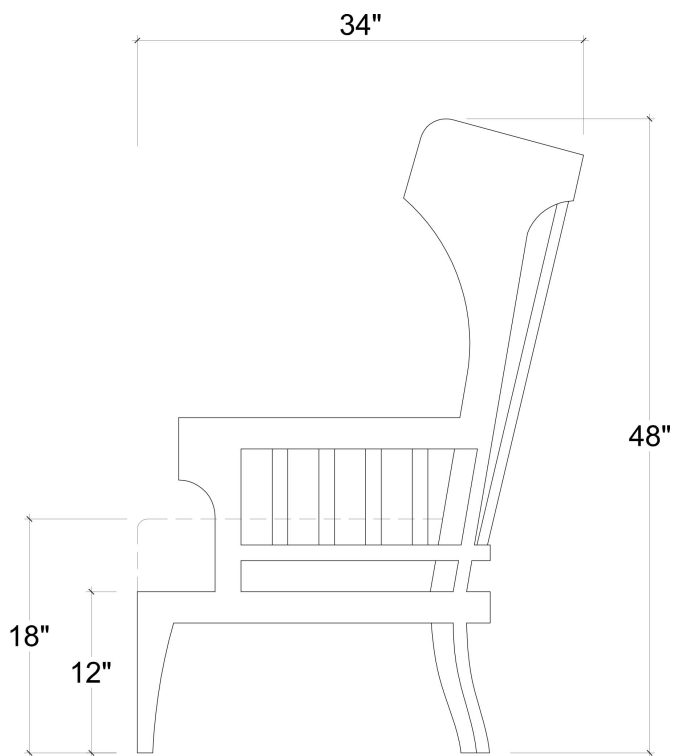

SIDE VIEW

Visual Highlights



Technical Specification

Dimensions	31W x 34D x 48H in	CBM	0.96
Number of Packages	1	Cubic Feet	33.9 ft³
Package 1 Dimensions	32.7 x 35.4 x 50.8 in	Package 1 Weight	92.59 lbs
Package Weight Total	92.59 lbs	Net Weight	81.57 lbs
Material	Mahogany, Linen		

<https://www.brambleco.com/27447>
