

EST. *B* 1991

BRAMBLE

PRODUCT TEARSHEET



Chest w/ 3 Drawers

Shown in: **MAR**

SKU: **76121**

Size: **38W x 20D x 35H in**



Overview

Chest of Drawers



TOP VIEW

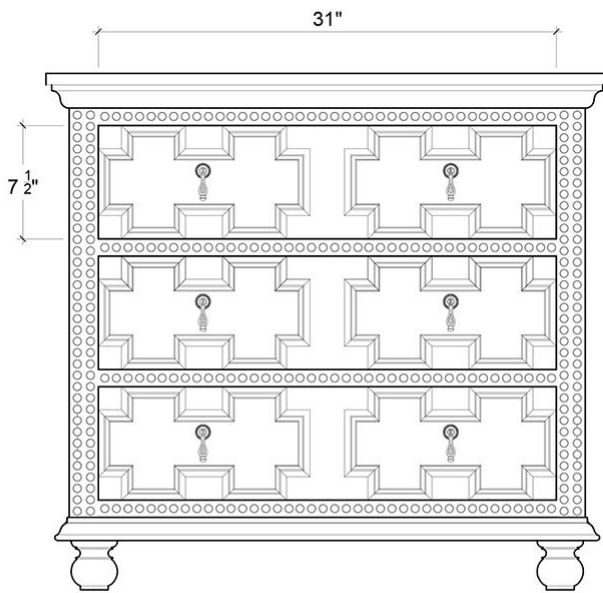

FRONT VIEW

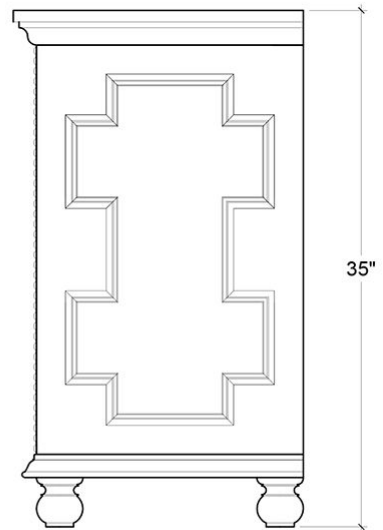

SIDE VIEW

Visual Highlights



Technical Specification

Dimensions	38W x 20D x 35H in	CBM	0.52
Number of Packages	1	Cubic Feet	18.36 ft³
Package 1 Dimensions	41.3 x 22.8 x 40.6 in	Package 1 Weight	121.25 lbs
Package Weight Total	121.25 lbs	Net Weight	110.23 lbs
Material	Mahogany		

<https://www.brambleco.com/76121>
